

WindSign Available in 3 sizes

- Springs connect the frame to the base allowing sign to resist strong winds and return to upright position.
- "Quick change" feature enables sign blanks to be changed in seconds and stay securely in place. No clips, bolts or special treatment.
- Sand or water fillable plastic base with factory installed wheels. Free funnel included to facilitate loading.
- Molded-in tie down hole allows for chaining or wiring the base, deterring theft.
- Attractive plastic frame design eliminates torn miters and jammed latches. Won't rust or splinter.
- Two-sided (holds two signs per frame). Can accommodate coroplast, aluminum, acrylic, or any foamboard.



Plasticade's Quick-Change Feature:



Slides in easily, and...



...stays securely in place!

Holds these sign blank sizes:

WindSign	22" x 28"
WindSign II	24" x 36"
WindSign III	28" x 40"

WindSign Available in 3 sizes



Molded-in handle and factory installed wheels assure easy mobility.

Assembles in less than 5 minutes

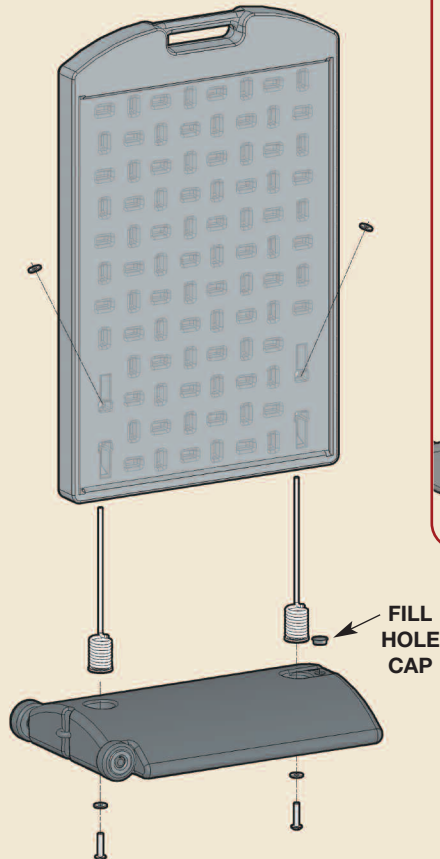

Sign frame and spring are easily assembled with the provided hardware. Only a screwdriver is required. Wheels are factory installed. Instruction sheet included. Assembles in less than 5 minutes.

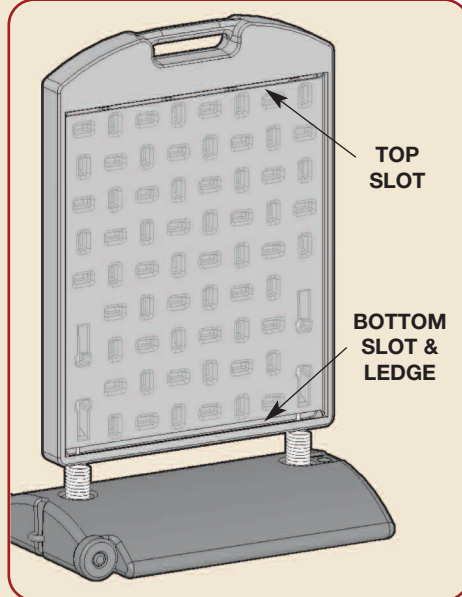

WindSign Dimensions:

WindSign: 32.75"h x 24"w x 2.5"d
(40"h x 26"w on base assembly)
weight: 11 lbs.

WindSign II: 40.75"h x 26"w x 2.5"d
(48"h x 26"w on base assembly)
weight: 12 lbs.

WindSign III: 44.75"h x 30"w x 2.5"d
(53"h x 30"w on base assembly)
weight: 16.7 lbs.

Base: 4.5"h x 26"w x 18"d
weight: 4.3 lbs.
(90 lbs. filled with sand)
(45 lbs. filled with water)

Each sign frame displays two signs.

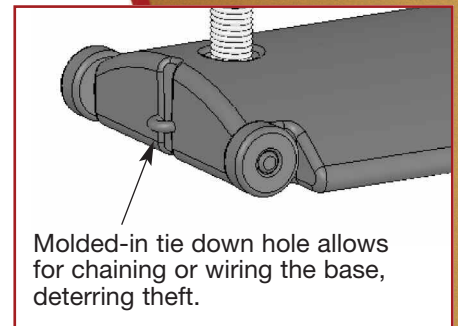

Molded-in tie down hole allows for chaining or wiring the base, deterring theft.

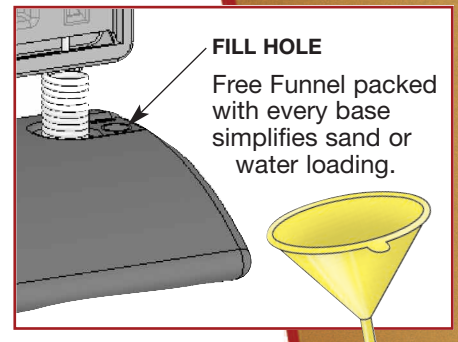

FILL HOLE
Free Funnel packed with every base simplifies sand or water loading.

Customize Your Sign

(See Accessories Sheet for more details.)

Slide in a Message Board...



or a Marker Board...

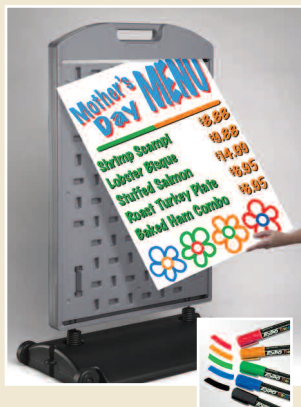

or a Graphic Sandwich



MADE IN THE USA
US PATENT 7,337,569

PLASTICADE PRODUCTS

7700 Austin Avenue
Skokie, IL 60077
phone (800) 772-0355
fax (847) 966-8074
www.plasticade.com